

**PRESENTATION**  
**ON**  
**ADHESIVES & COATINGS**

**BY**

**CHEMLINE**  
**I N D I A L T D**

(An ISO 9001:2015, 14001:2015 & 45001:2018 Certified Company)

## BACKGROUND OF CHEMLINE

- **Established in 1990.**
- **An ISO 9001 : 2015, ISO 14001 : 2015 & ISO 45001 : 2018 Certified.**
- **Manufacturer & Exporter of Industrial Adhesives, Coatings, Varnishes, Hot Melts, Speciality Waxes and Jelly Glues.**
- **Number of Employees 300+**

## OUR STRENGTHS

- **An R & D Based Company.**
- **Chemline is headed by a Technocrat Dr. Ravindra Nath Goel  
(Ph.D - IIT Delhi)**
- **Entered the Industry through Innovating Novel Products.**

# INNOVATIONS DONE BY CHEMLINE

- **First to make Polymer Based Labeling Adhesive & Ice Water Resistant Adhesive replacing Dextrin/Casein based adhesives**
- **First to produce Hot Melt Adhesives for Plastic to Paper / Board bonding based on APP (Side product of polypropylene plant)**
- **First to make Water Based Lamination Adhesives in India for Automatic High Speed Lamination Machines for both - Offset & Flexible Packaging Industry.**
- **Heat Sealable Water / Oil Proofing Coating for Paper / Board for application in Food wrapping & Paper Cups  
(As a replacement for LDPE Coating / Plastic Packaging)**
- **AL-AL foil sealing application using water based coating**

# AWARDS



**COMPANY OF THE YEAR-2019 (PACKAGING)**  
**AWARDED TO CHEMLINE INDIA LTD BY ZEE BUSINESS, 'DARE TO DREAM' AWARDS.**  
**DR RAVINDRA GOEL, FOUNDER CHAIRMAN AND MANAGING DIRECTOR OF**  
**CHEMLINE INDIA LTD FELICITATED BY SH. ANURAG THAKUR,**  
**UNION MINISTER OF STATE FOR FINANCE AND CORPORATE AFFAIRS, GOVT OF INDIA.**



30 नवम्बर 2016 को गुरुग्राम में राज्यस्तरीय एक्सपोर्ट अवार्ड वितरण समारोह में माननीय मुख्यमंत्री श्री मनोहर लाल खट्टर से निर्यात के क्षेत्र में उत्कृष्ट प्रदर्शन के लिए अवार्ड लेते हुए कैमलाइन इंडिया लिमिटेड धतूरी सोनीपत के प्रबन्ध निदेशक डा. रविन्द्र गोयल।

# FACTORY SETUP – TOP VIEW



# FACTORY SETUP



# RESEARCH & QUALITY ASSURANCE WING



**Brookfield Viscometer**



**QC Lab**



**PH Tester**



**Constant Humidity Chamber**



**Gas Chromatograph**



**Heat Oven**



## EXPORT ACTIVITIES

Chemline exports its products to about **45 Countries**

- **Europe**
- **The Middle East**
- **Latin America**
- **South East Asia**
- **Countries of Africa**
- **CIS**

Exporting world-wide either directly to the customers or through our network of Agents and Distributors.

# GLOBAL PRESENCE

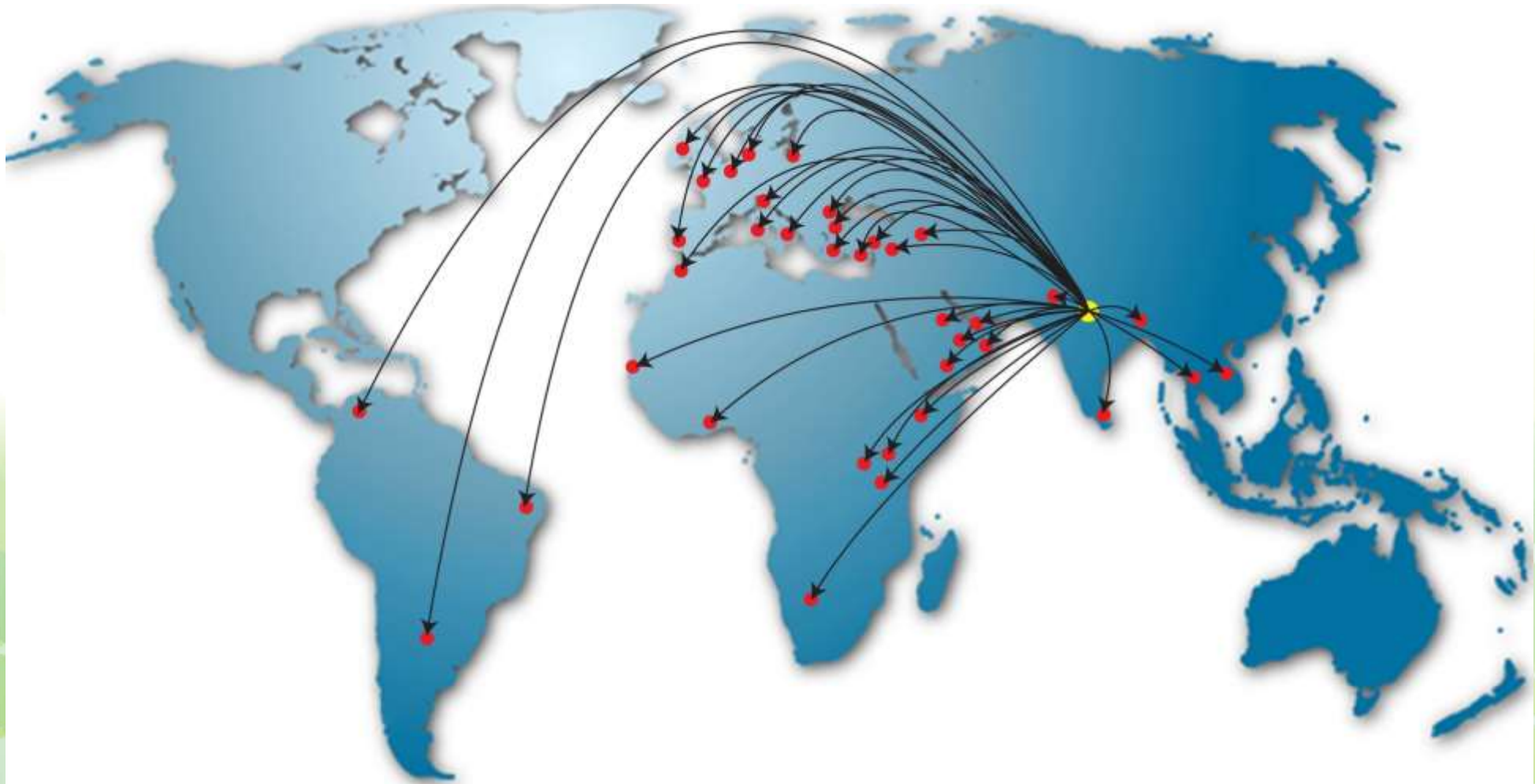



**OVER 500+ ADHESIVES & COATINGS  
FOR VARIOUS APPLICATIONS**

**Bottle Labelling for Breweries, Distilleries, Beverages, Food & Pharma**

**Paper Printing, Packaging & Converting Industry**

**Barrier Coatings for Food Packaging**

**Speciality Hot Melts for Various Industrial Applications**

**Adhesives for Flexible Packaging Industry**

**Industrial & Packaging Tapes**

**Printed Product Labels**

**Self Adhesive Label Stocks for printed Label Applications**

**Rigid Plastic Packaging**

# PAPER PRINTING & PACKAGING INDUSTRY

**CHEMLINE – Always Ready to Meet Emerging Market Requirements**

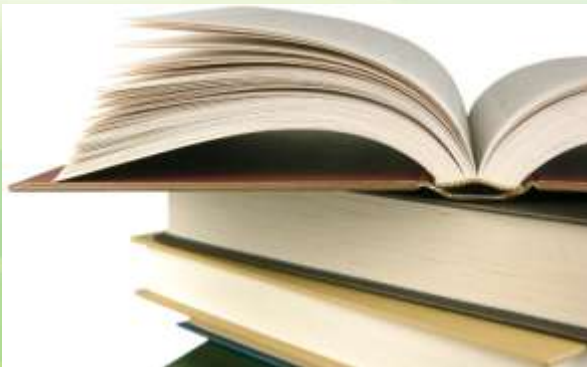

## PAPER PRINTING, PACKAGING & CONVERTING INDUSTRY

**WATER BASED ADHESIVES** : Paper to Film Lamination

**PU BASED ADHESIVES** : Paper to Film Lamination

**VARNISHES** : UV Varnishes & Aqueous Varnishes and Primers

**HOT MELT ADHESIVES** : Perfect Book Binding

**HOT MELT / COLD ADHESIVES** : Carton Side Pasting / Closing

**JELLY GLUE** : Case Making & Rigid Box Making

**WATER BASED COLD GLUES** : Miscellaneous Purpose

**HOT MELT AND WATER BASED ADHESIVES** : Pressure Sensitive Applications

## Water Based Adhesives : Paper to Film Lamination

### CHEMICRYL

#### ➤ Dry Lamination

**Application:** All Acrylic Type Products for Lamination of Films like PET, PVC, BOPP, MPET to Paper / Duplex Board at High Speed of > 60 mtr /min. Especially for Lamination of MET PET/Holographic Film.



## Water Based Adhesives : Paper to Film Lamination

### CHEMICRYL

#### ➤ Wet Lamination

**Application:** Especially for Lamination of PET Film apart from OPP & PVC, MPET with Paper or Duplex Board, Outstanding Grade for Creasing, Embossing, Guttering & Lamination of Dark Substrates. Lamination of Films like BOPP, PVC to Paper or Duplex Board.



## Paper to Film Lamination, Monocomponent PU Based

### CHEMICRYL

#### ➤ PU Lamination

**Application:** Solvent Less Monocomponent Polyurethane Lamination for Steinmann Type machines.





## UV Varnishes, Primer Coat & Blister Coatings

### CHEMIGLOSS & AQUAGLOSS

**Product:** UV Varnishes for Texture/Drip-off effect with Online, Duct & Coater Applications. UV Varnishes for Online & Offline Applications. UV Varnish for Heat Set Printed Paper. Spot UV Varnishes for Screen Applications.



## UV Coatings

### CHEMIGLOSS & AQUAGLOSS



## Spot UV Varnishes for Screen Applications

### CHEMIGLOSS & AQUAGLOSS

**Grade:** UVS 600 PR & UVS 600 PRL

**Application:** Spot UV Varnish for Paper, Board and MET PET / BOPP films through Screen application.



# Water Based Over Print Varnishes for Online/Offline Applications

## BLISTER COATING



## Hot Melt Adhesives for Book Binding

### QUIKLOCK

**Product:** Hotmelt Book Binding Adhesives for Perfect Binding (For Muller Martini, Kolbus M/c's) etc.

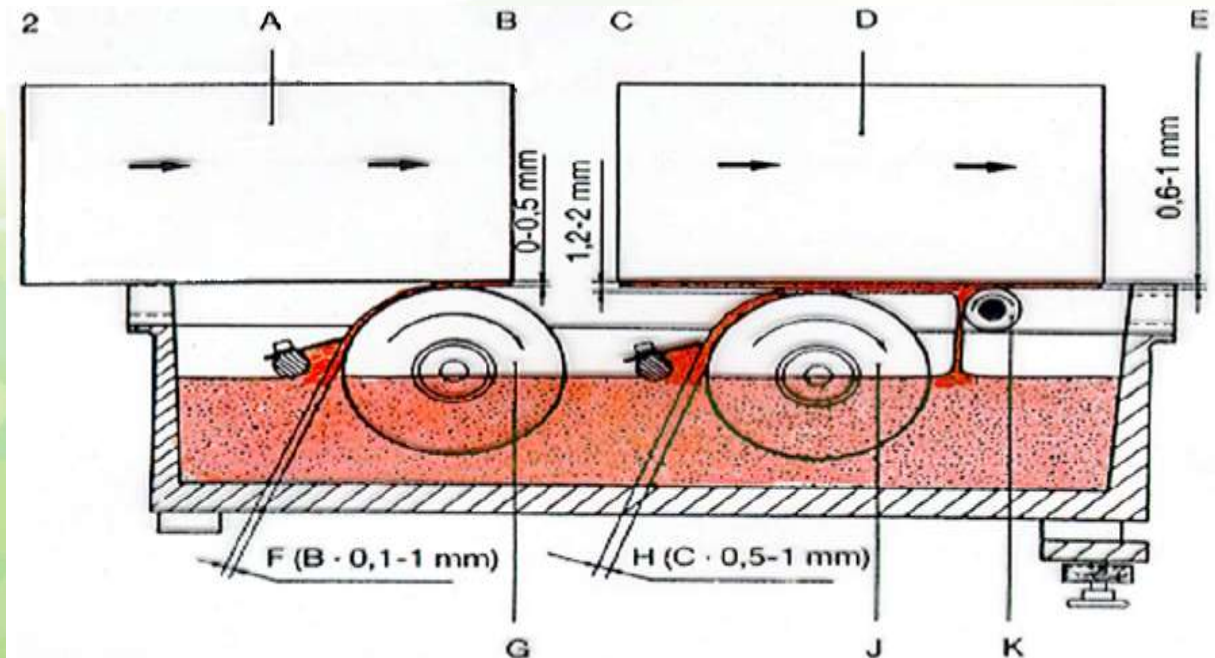

## Animal Jelly Glues

### QUIKLOCK

**Products:** Animal Jelly Glue for Hard Case/Rigid Box Application for Kolbus, Harouf, Memory, Mega Bound Type Machines.

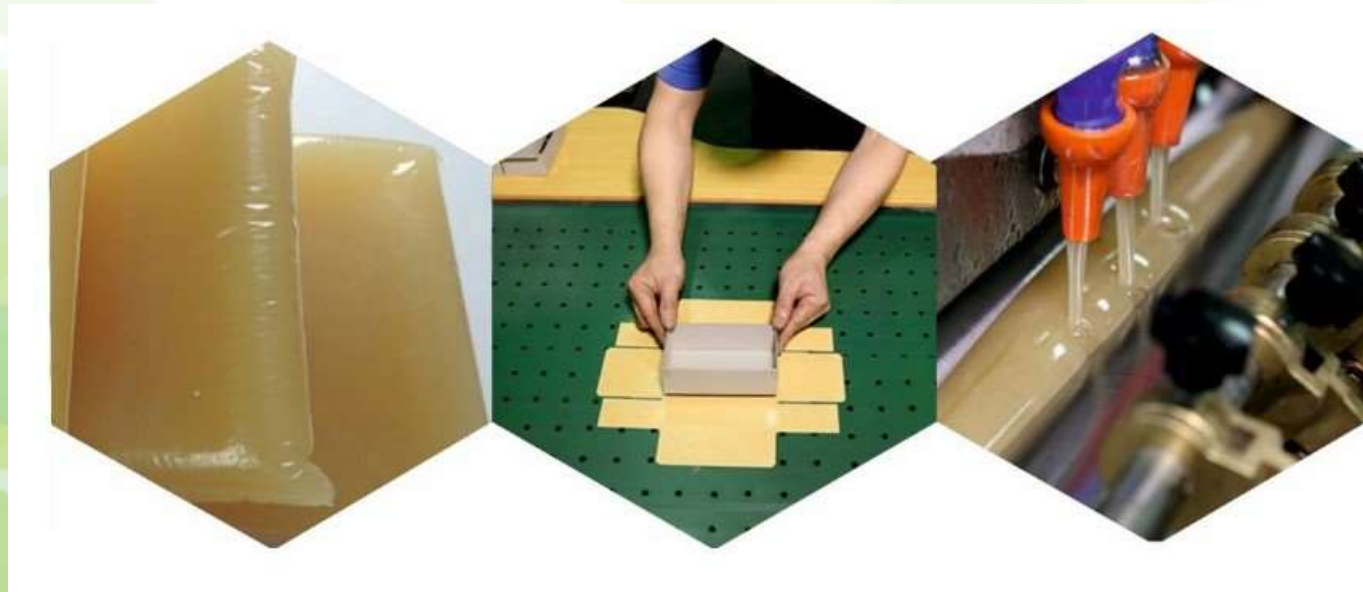

## Water based Rigid box making

### QUIKLOCK

**Products:** Animal Jelly Glue for Hard Case/Rigid Box Application for Kolbus, Harouf, Memory, Mega Bound Type Machines.

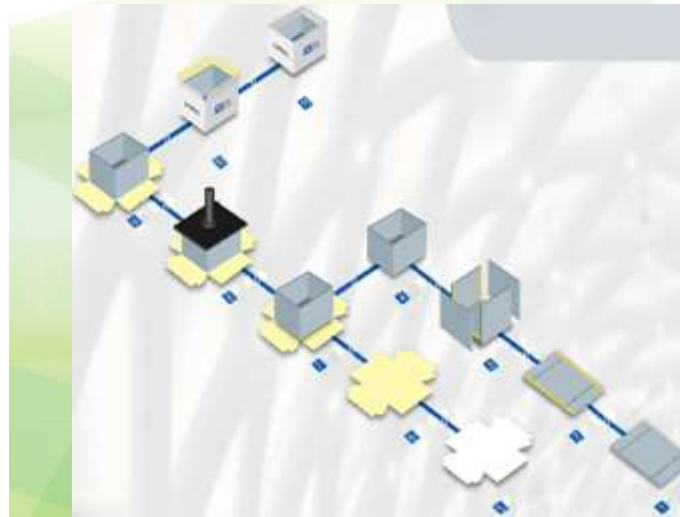

## Carton Side sealing (Folder Gluer)

### QUIKLOCK

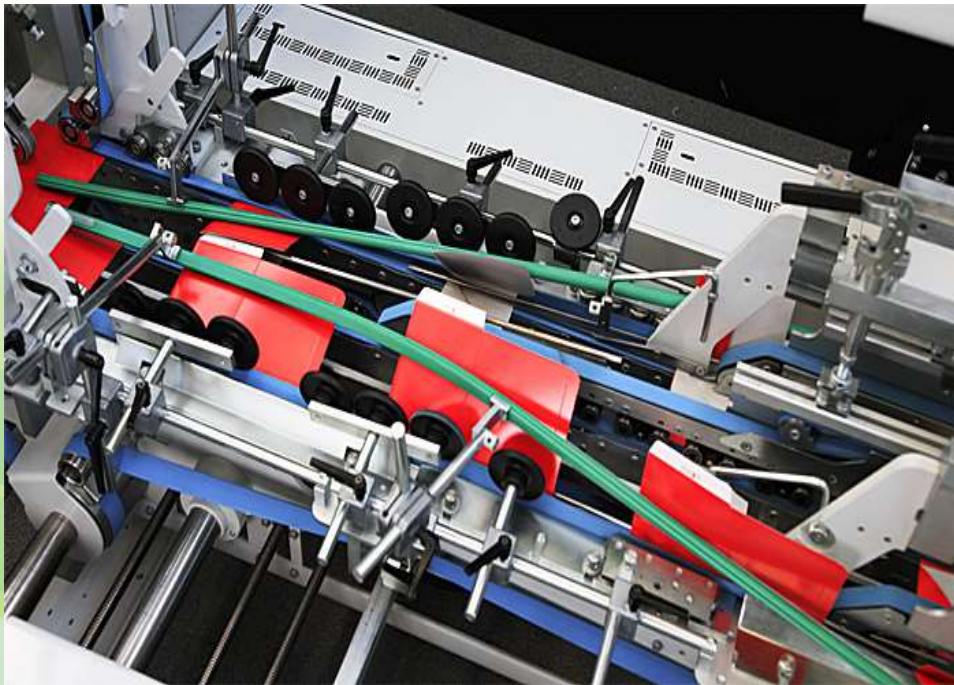



## Flute Lamination Adhesive

### CHEMICRYL

**Products:** Carton Side/Flap & Shell Pasting, Cold Book Binding Adhesive for Casing in Application, Cold book Binding Adhesives, Carton Liner Pasting Adhesives.



# ADHESIVES & COATINGS FOR FLEXIBLE PACKAGING INDUSTRY

## CHEMLINE - Always Ready to Meet Emerging Trends



## ADHESIVES & COATINGS FOR FLEXIBLE PACKAGING INDUSTRY

**PU BASED** - Solvent Free & Solvent Based Lamination Adhesives

**ACRYLIC BASED** – Water Based Lamination Adhesives

**HOT MELTS** - For Side Sealing of Woven/Raffia Bags

**ACRYLIC Co-POLYMER RESINS** - For Various Applications

**OVER PRINT VARNISHES** - UV, Aqueous & Solvent Based

**HEAT SEAL COATINGS** - Pouch making & Pharma Blister

**HOT MELTS & WAXES** - Soap/Chewing gum Wrappers, Hot Foil Stamping, WADS Etc.

**RELEASE LACQUER, COLD SEAL COATINGS**

**ADHESIVES** - PAPER METALLIZATION

## HEAT SEAL LACQUER COATINGS

### CHEMISEAL

**Products:** Heat Seal Lacquer

**Applications:** Used for Coating of Al Foil to Al Foil, Al Foil to PVC, Paper to Paper Sealing Application.

#### **Key Benefits:**

- Enhances shelf appeal with superior clarity.
- Excellent sustainability from water-based chemistry.
- Productivity improved through increased line speeds
- Low Coating Weight Suitable for Heat Sensitive Items
- High Seal Strength and No Chance

## HEAT SEAL COATINGS

### CHEMISEAL

#### Product Advantages

- Ensure Plastic Waste Management & Direct Food Contact Compliance.
- Increase efficiency with excellent Hot tack, Low Seal Initiation Temperature, and a wide CoF (Coefficient of Friction) range.



## RELEASE LACQUER / PRIMER FOR PET / PAPER

### CHEMISEAL / AQUASEAL

**Products:** Release Lacquer

**Applications:** Coating on PET Film for Transfer Metallization & Transfer Printing.

**Products:** Primer For Pet & Paper

**Applications:** Metallization Primer for Paper & PET Film.

Transfer metallization on board using release coat



## HOT MELT & WAX COATINGS

### CHEMISEAL / AQUASEAL

**Products:** Wax Coating For Paper / Toffee Twist Wrapper.

**Applications:** In Paper Coating for Food Packaging & Toffee Twist Wrapper for Moisture Impermeable Characteristics.



**Products:** Hot Melt Soap Wrapper Coatings.

**Applications:** For Inner Coating, Heat Sealing of Soap & Chocolate Wrappers and for Chewing-Gum Wrappers.



## HOT MELT & WAX COATINGS

### CHEMISEAL / AQUASEAL

**Products:** Lamination Wax (Al-Foil/Paper)

**Applications:** For Butter Packaging.



**Products:** Lamination Wax & Induction Adhesive for WAD

**Applications:** For Lamination of Al Foil with Paper/ Board for WAD making & For Induction Sealing of Glass Containers.





# BARRIER COATINGS

## AQUACOAT

**Coating On :** Coated and Uncoated Paper and Paper Boards

### **What is Barrier Coating ?**

Barrier coatings are used to restrict the flow of oil, grease, water, oxygen or moisture through a variety of materials in order to offer better protection. The ability to control this flow is very useful in many applications, especially in food packaging products like Paper Cups, Paper Plates, Pizza and Burger Boxes Etc.

### **Why Barrier Coatings?**

- Fully Eco-Friendly and Pollution Free
- No Harm to Health
- Excellent Water, Oil and Grease Resistant Property
- Good Drying Characteristics
- Very Good Rub Resistance

## BARRIER COATINGS

### AQUACOAT

#### Two Type of Barrier Coatings

1. Heat Sealable Barrier for Paper Cups
2. Non Heat Sealable Barrier for Paper Plates, Pizza Boxes and Burger Boxes



**Paper Cups**



**Paper Plates**



**Pizza Boxes**



**Burger Boxes**

## BARRIER COATINGS

### AQUACOAT

#### Product Advantages:

- Heat Resistant
- Food Contact Approved .
- Good Heat Sealability.
- Good Machine Running Characteristics .
- Suitable for Coated and Uncoated Paper Boards
- Coating Applications on High Speed Gravure and Air Knife Machines.
- Very High Optical Clarity .
- Water Repellency with Cold , Hot Water and Aerated Drinks

# SPECIALITY HOTMELT ADHESIVES

**CHEMLINE – Always Ready to Meet emerging Market Requirements**



## SPECIALITY HOTMELT ADHESIVES

**HYGIENE** : Diapers and Sanitary Napkins

**END OF LINE PACKAGING** : Carton & Case Sealing

**PET BOTTLE LABELLING** : Mineral Water & Carbonated Drinks

**FREEZING CARTON** : Ice Cream, Frozen Foods & Medicine

**HMPSA** : Label Stocks, Holograms and Industrial & Medical Tapes

**AIR & AUTOMOTIVE** : Air Filter Assembly, Head / Tail Lamp Assembly

**MATRESSES**: Spring Pocket Bonding and Foam Assembly

**BAG SEALING** : WPP Bags & Courier Bags for E-Commerce

**PPE KITS SEAM SEALING** : Adhesives & Tapes

**ANTI-SKID ADHESIVES**: Carpet Back Coating & Anti-Skid Palletization

## HOTMELT ADHESIVES: TYPES & PHYSICAL FORM

Hotmelt  
Adhesives

Ethyl Vinyl  
Acetate



Metallocene



Polyolefins



Styrene Isoprene  
Styrene



## ADVANTAGES OF METALLOCENE OVER EVA - BASED HOTMELTS

- **No string formation at high speed packaging lines.**
- **Eliminates Char or Gel formation**
- **Excellent Pot life due to high thermal stability.**
- **Remains clear in pot after prolonged periods.**
- **Lowest application temperature and Energy Saving.**
- **Higher mileage**



**EVA Based**



**Metallocene  
Based**

## CARTON CLOSING ADHESIVES

**EVA BASED ADHESIVES : CH125 F12 - Non Laminated Cartons**

**EVA BASED ADHESIVES : CH 90 F12- Low Melting**

**METALLOCENE BASED ADHESIVES : CH 135 WFM (3) – Non Laminated Cartons**

**METALLOCENE BASED ADHESIVES : CH 135 WFM (-308) – Deep Freeze & Laminated**



# Hotmelt Adhesive Application – Hygiene Industry For Baby & Adult Diapers

- Construction Adhesives
- Positioning Adhesives
- Elastic Attachments

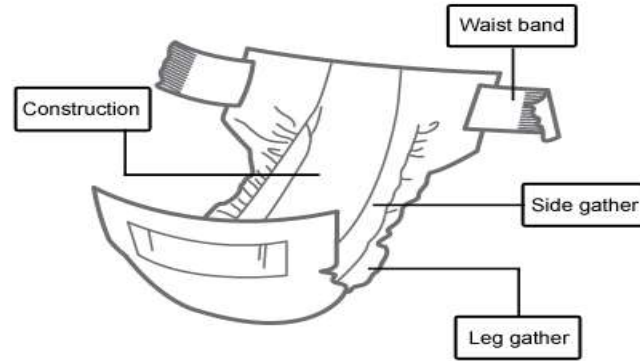

## Application Areas



## Hotmelt Spray



# Hotmelt Adhesive Application – Hygiene Industry

## Sanitary Napkins

- **Sanitary napkins market was only 24% in 2016, (% of Females using). This figure is expected to grow to 42% by 2020.**

- **Construction Adhesives**
- **Positioning Adhesives**

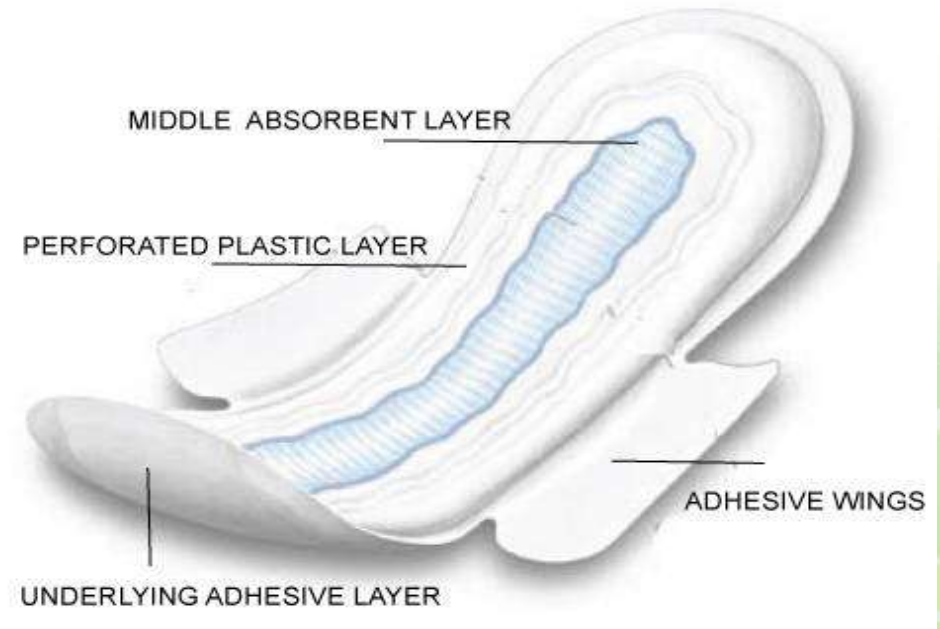

**Application Areas**

# EMERGING TRENDS IN HOTMELT ADHESIVE – END OF LINE PACKAGING APPLICATIONS

Industry	Application- Hotmelt
End of Line Packaging	Vertical / Horizontal Cartoning
	Case Erector / Case Sealer
	Wrap Around Case Packing
	Frozen Foods Carton Sealing
	Top Loading
	Tray Packing
	Pharma Carton Sealing
	Pharma - Outsert application
	Temper Evident Closure
RIM Paper Wrapping	



Case Erector/Case sealing



Wrap Around Case Packing



Tray Packing

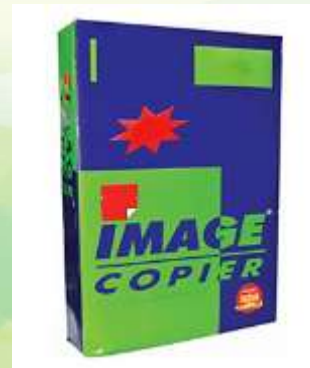

RIM Paper Wrapping



Top Loading



Tamper Evident Closing



Carton Sealing ( Food & Non-Food)

# Hotmelt Adhesive Application – Beverages

## Bottle Labelling

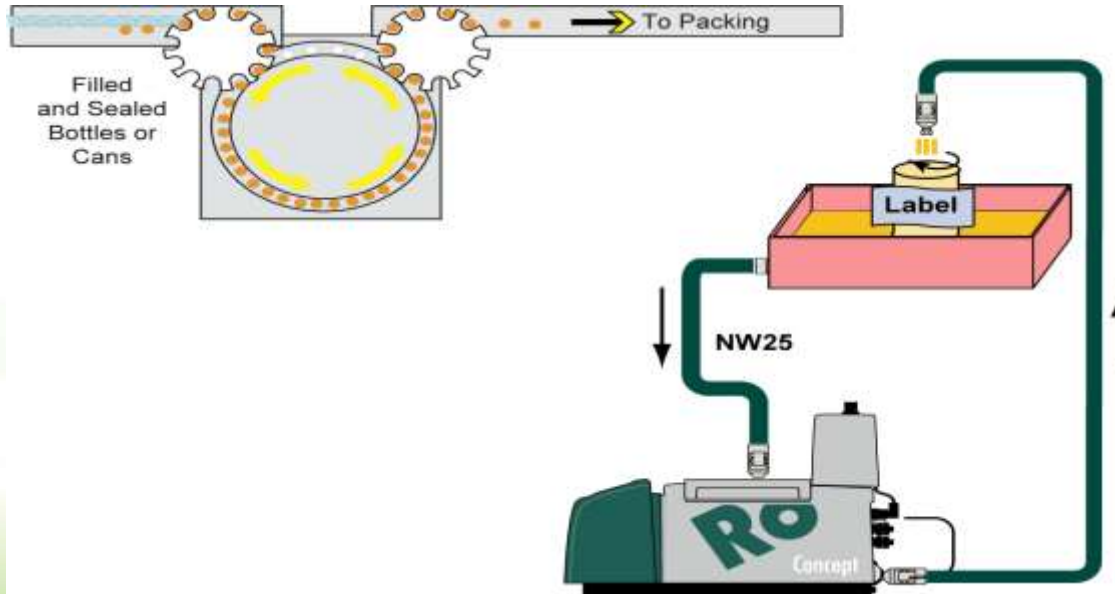

Labelling Process – Pot Filling

Labelling Process – Nozzle Based



# Hotmelt Adhesive Application – Beverages

## Straw Attachment and Lid Fixing

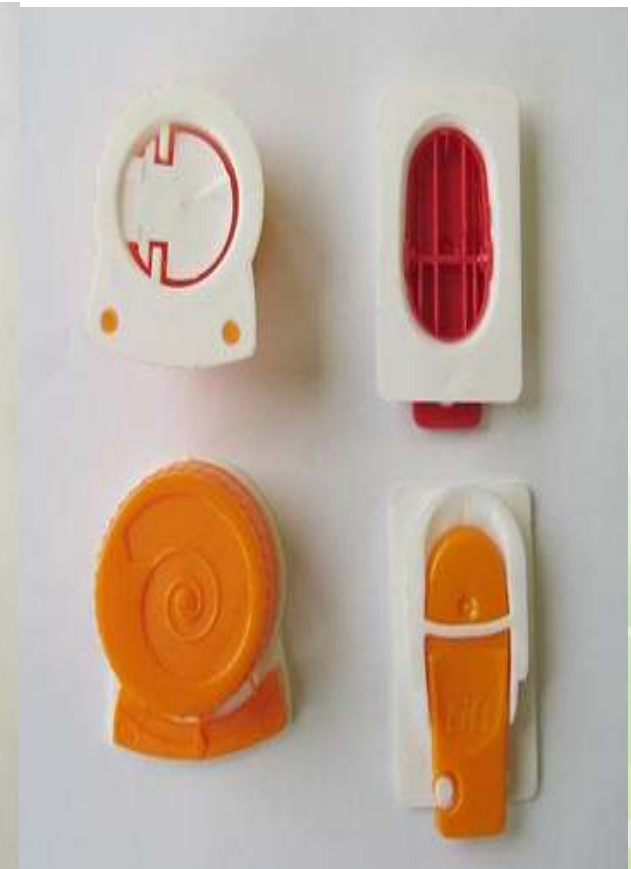

**Tetra Pack – Straw Attachment**

**Tetra Pack – Lid Fixing**

# Hotmelt Adhesive Application & It's Suitable Grades

S.No.	Industry	Segments	Application	Chemline - Adhesives Grades
1	Packaging (End of Line)	Beverages	Wrap Around Case Packing	CH-125 F12, CH-125 FMW
		Food	Case Erecting/Closing	CH-125 F12, CH-125 FMW
		Non Food	Tray Erecting/Packing	CH-125 F12, CH-125 FMW
		Pharma	Top Loading	CH-125 F12, CH-125 FMW
		Paper	Fruit Tray Erector	CH-125 F12, CH-125 FMW
		Miscellaneous	Vertical / Horizontal Carton Sealing	CH-125 F12, CH-125 FMW, CH-135 YBL, CH-135 WFM
			Frozen Foods Carton Sealing	CH-125 YFM, CH-135 WFM
			Contactless labelling	CH-9026 THS, CH-9026 YMS
			Pot Filling for Labelling	CH-9026 THS, CH-9026 YMS
			Straw Application	CH-190 SB
			Temper Evident Closure	CH-125 F12, CH-125 FMW
	Pharma - Outsert Pasting	CH-9028 LRW		
2	Converting (Paper/Corrugation)	Paper	Envelope Production	CH-9028 L
		Solid Paper Board	Folding Gluing Solid Board	CH-125 F12, CH-125 FMW
			Folding Gluing Solid Board-Frozen Foods	CH-135 YFM, CH-135 WFM
			Courier Bag Side Sealing	CH-9028 LT
			WPP bag making	CH-9028SS, CH-9028 SSHY
			FIBC bag making	CH-9028 L
			Ice cream cone making	CH-135 WFM
			Label Stock	CH-9028 L
	Holograms	Ch-9028 L5		
3	Hygiene	Sanitary Napkins	Construction Adhesive	CH-9028 LC3, CH-9028 LCW
		Baby/ Adult Diapers	Positioning Adhesive	CH-9028 LP3, CH-9028 LPW
		Adult Diapers	Elastic Attachment	CH-9028 LE1

# Hotmelt Adhesive Application & it's Suitable Grades

S.No.	Industry	Segments	Application	Chemline - Adhesives Grade
4	Wood Processing	Solid Wood Processing	Edge Banding	CH-8540 WA, CH-8520 WA
		Chair Assembly	Foam to Fabric bonding	CH-9028 L
5	Automotive	Automotive – Subcontractors	Interior Foam Assembly	CH-9028 L
			Head/Tail Light Assembly Sealant	CH-9028 HL
6	Various Industry	Shoe Industry	Shoe Fabric Lamination	SFL-89 TY
		Ceramics Industry	Tiles Carton Sealing	CH-125 H
		Air/Automotive Filter	Filter Assembly- Pleating	CH-9105 J2A, CH-9103 JY, CH-9103 JW
		Medical	Non-Woven Surgical tapes	CH-9028 L3
		Tapes	Industrial Tapes	CH-9028 L2, CH-9028 L5
		Carpet	Anti-Skid Carpet back Coating	AS-3090 W
		Shrink Sleeves	Shrink Sleeves Tube Making	CH-LS 30
		Mattress	Spring Pocket Bonding	CH-135 M6
		Waxes	Lamination Wax	CH-800 W
		Soap Wrapper	Soap Wrapper hotmelt Coating	SWC - 25 LH
Geo-Textiles	HDPE film to PP Non-Woven	CH-25 GT		

# LABELLING ADHESIVES

**CHEMLINE – Always Ready to Meet emerging Market Requirements**





## ADHESIVES FOR BOTTLE LABELING

**BREWERIES:** Ice Water Resistant Labeling Adhesives

**DISTILLERIES & FOOD:** Cold Labelling Adhesives For Distillery & Processed Food

**PHARMA:** Cold Labelling Adhesives for PET & HDPE Bottles

**BEVERAGES:** Hot Melt Adhesives For PET Bottle Labelling



# DISTILLERIES & FOOD: Cold Labelling Adhesives For Distillery & Processed Food Industry

## CHEMIGUM

**Products:** Cold Labeling Adhesives for Distillery & Processed Food Industry.

**Applications:**

1. For High & Slow Speed Pumps type Automatic Machines.
2. For Manual / Hand Gumming Machines.
3. For High & Slow Speed Pump Type Automatic Machines.
4. For Automatic Pot Type Machines.



# PHARMA: Cold Labelling Adhesives For Pet & HDPE Bottles

## CHEMIGUM

**Products:** Cold Labeling Adhesives Pet & HDPE Bottles.

**Applications:**

1. Suitable for Paper to PET Bottles on Pump/Pot type Machines. Products are stain free & fast drying.
2. For Automatic & Manual Hand Gumming Machines.

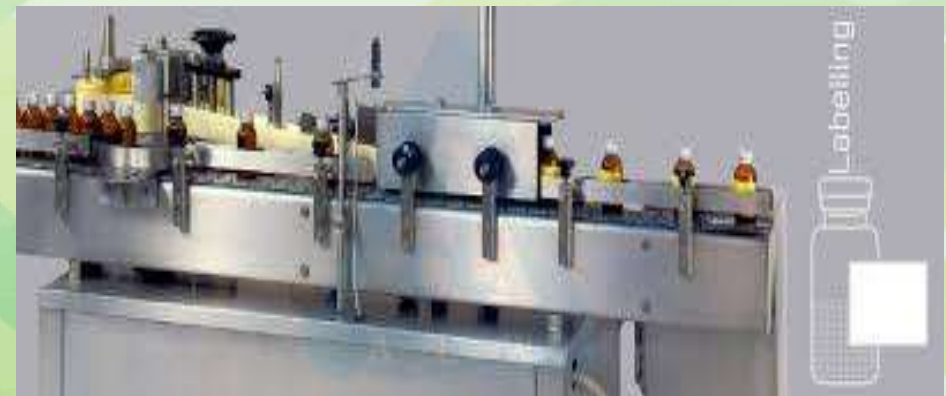

# Beverages: Hot Melt Adhesives For Pet Bottle Labelling

## QUIKLOCK

**Products:** Hot Melt Adhesives For Pet Bottle Labelling for Beverages.

**Applications:**

1. For High Dry Tack.
2. Labeling of PET Bottles for Beverages and Mineral Water Industry.



Hot Melts for PET labeling



# Hotmelt Adhesive Application – Beverages

## Bottle Labelling

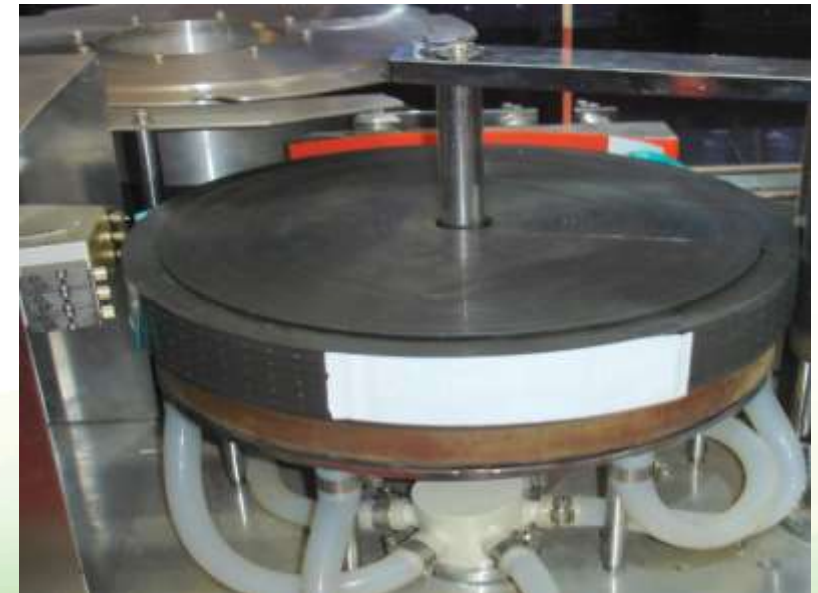
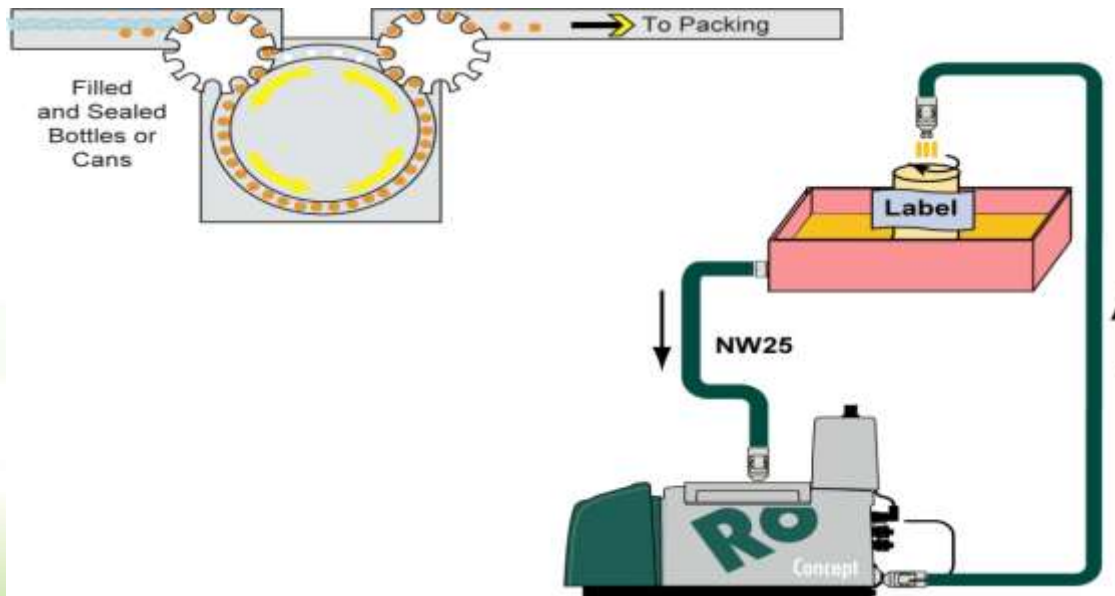

Labelling Process – Pot Filling

Labelling Process – Nozzle Based



# Hot Melt Adhesive Application – End of Line Packaging



**Carton Sealing**



**CASE PACKER MACHINE**



**EVA and Metallocene Based Hot Melts for Packaging**

## PRINTED LABELS ( WET GLUE AND SELF ADHESIVE LABELS )

Venturing in a big way into the manufacturing of Printed Labels i.e., WET GLUE and SELF ADHESIVE LABELS , keeping in view of various Industrial requirements in India and abroad i.e.,

- Wet strength labels for Breweries
- Wet Glue labels for Distilleries ,Pharma, Food industries etc..
- Self Adhesive Labels ( Paper & Film)
- BOPP Wrap around labels

# Wet Glue & Pressure Sensitive Labels

**Chemline India Ltd. has made a major investment to delight customers in meeting their printing needs including:**

- **Shorter runs**
- **Precise registration**
- **Complex Labels with a wider range of Colors.**



**Pressure Sensitive labels for industries like Pharma, Cosmetics, Lubricants etc**



**Wet Strength Labels for Breweries**



# Wet Glue & Pressure Sensitive Labels

**Stand out among the competition with better product positioning and eye catching creative labels.**



**Wrap Around Labels & Shrink Sleeves  
for Beverages**



**Distillery Labels**

# LABEL STOCKS



# LABEL STOCKS MACHINE



## TYPES OF PAPER LABEL STOCK

**UNCOATED** (Maplitho, Vellum) : Gun Labels , Book Labels

**MID GLOSS** (Chromo Paper) : Product Labels

**GLOSS COATED** (Mirror coat , Cast coated , Cast Gloss) : Liquor Labels

**COLORED PAPERS** : Promotional Labels

**THERMAL TRANSFER** : Barcode



## TYPES OF PAPER LABEL STOCK

**DIRECT THERMAL:** Barcode

**THERMAL BOARD :** Air Line Boarding Pass

**WET STRENGTH :** Liquor Labels for Ice Bucket Application

**TAMPER EVIDENT :** Excise Label on Liquor Bottle

**TYRE & ROUGH LABELLING :** Tyre , Jute Bag, Army Uniform, Shoes



## TYPES OF PAPER LABEL STOCK

**HOLOGRAPHY** : Medicines, Books

**VOID** : Mobile Boxes

**DIGITAL**: Less Quantity & Premium Quality

**VAC & FOILS** : Premium Beer Bottles for aesthetic look



## TYPES OF FILMIC LABEL STOCK

**PP White** : Rigid Plastic Container – Home & Personal Care

**PP Clear** : Rigid Plastic Container – Home & Personal Care

**PP Silver** : Rigid Plastic Container – Home & Personal Care



## TYPES OF FILMIC LABEL STOCK

**PE White** : Lamitubes – Home & Personal Care

**PE Clear** : Lamitubes – Home & Personal Care

**PE Silver** : Lamitubes – Home & Personal Care





## TYPES OF FILMIC LABEL STOCK

**PET White** : Durable Labelling

**PET Clear** : Durable Labelling

**PET Silver**: Durable Labelling

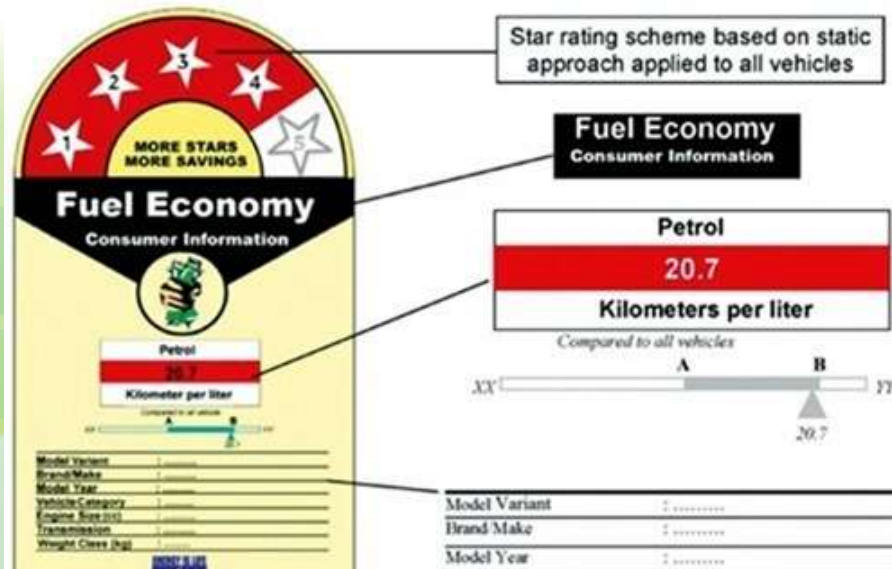

## **OTHER MISCELLANEOUS PRODUCTS INCLUDE**

**INDUSTRIAL & PACKAGING TAPES**

**PPE KITS TAPES**

**GENERAL PURPOSE MASKING TAPES**

**KRAFT PAPER TAPES**

**DOUBLE SIDED TISSUE TAPES**

**HEAT SEAL CORNER TAPES – PAPER AND PET**

# INDUSTRIAL & PACKAGING TAPES



# BOPP TAPES

## BOPP Tape (Super Clear)

Transparent Tape with “No bubbles” & Clear to core.

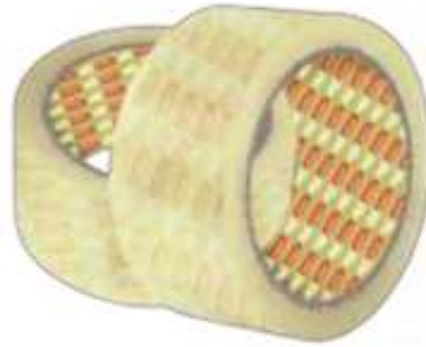

## BOPP Low Noise Tapes

When tape is having used it will create very Low Noise. And needed in many places.



# BOPP TAPE - PLAIN / PRINTED / COLORED

## Description

BOPP Tapes Adhesive tapes are made from superior quality adhesive and water base acrylic adhesive, which provides high tack and adhesion strength required for sealing of cartons to make them pilfer proof.



Brand	Standard	Color	Core Id	Thickness
CHEMLINE- QUIKTACK	Length			(micron)
				35 ± 1
				37 ± 1
	(65 & 650 Mtr)	(Brown & Transparent )	(Inner Diameter of Core-76 mm)	40 ± 1
				44 ± 1
				49 ± 1
				54 ± 1



# CREPE PAPER TAPE

## Description

A premium and economical grade general purpose Crepe paper masking tape provides excellent Pressure Sensitive and quick qualities and resistance to water, solvents and oils.



## Features

- Writable tape.
- Excellent adhesion, easy to tear.
- Strong climate adaptability.
- Interior paint masking, light duty packaging, bundling, holding, splicing & tabbing, silk screening, and other non-critical applications where a pressure-sensitive tape is needed.



# KRAFT PAPER TAPES

## Description

- ❖ Self Adhesive Paper Tape can be quickly and neatly applied direct to the package or box, often from a dispenser.
- ❖ It is available in a variety of widths as per customer requirements.
- ❖ Kraft Paper Tape has another advantages, it can be recycled as it is a biodegradable and environment friendly.
- ❖ There are two types of Paper Tapes – Plain & Printed.

## Features

- ❖ Kraft Paper Tape is made of good paper and high grade adhesive.
- ❖ Paper Tape is eco-friendly and it can be a good substitute of any other filmic or Bopp tape.
- ❖ Paper Tape is used for sealing up boxes and packages for shipping and transit .
- ❖ It is ideal for long haul, cardboard box or perhaps even for art.



# DOUBLE SIDED TISSUE TAPES

## Description

- ❖ Chemline India Ltd. Is an Indian adhesive and adhesive tape manufacturer that focuses on the customer specific requirements .
- ❖ Double Sided Tissue Tapes are made from non-woven Tissue Paper coated on both sides with acrylic adhesive and laminated with release liner.
- ❖ Double Sided Tissue Tapes are recommended for mounting light objects and may be used to laminate and fix foams , felts, papers, plastics films, foil and textiles.
- ❖ It is also used in television sets and LED , earphone, loudspeakers, sound boxes and gift wrapping.

## Features

- ❖ Double Sided Tissue tape with two sided is made of lightweight tissue .
- ❖ This tape has a strong stickiness that allows for a variety of uses.
- ❖ These adhesive tapes may be used in splicing.





# HEAT SEAL CORNER TAPES

## Description

- ❖ Heat Seal is used for bonding together of direct Mail, Bank notes, Cell Phone Boxes and Food and Sweet Box during manufacturing.
- ❖ They are two types of tapes – One is Paper Based and Second is Polyester Based.
- ❖ This Kraft Paper or polyester based tapes forms a heat activated bonding to seal.



## Features

- ❖ These tapes are 100 % Chemline India Ltd. Products and made in house.
- ❖ Easy in application .
- ❖ Quick stick to the surface.
- ❖ Best in quality
- ❖ Hundreds of satisfied customers.



## Hot Melt Adhesives



## Water based Acrylic Adhesives



# ADHESIVE & TAPES for PPE Kits

- **HIGH PERFORMANCE ADHESIVES for Seam Sealing of PPE KITS (Personnel Protective EQUIPMENT) used by Doctors and Health Workers for fighting COVID - 19.**
- **Tapes made from above High Performance Adhesive are used on Hot Air Seam Sealing Machines.**
- **Our High Performance Adhesive Provides Excellent Bonding between PP Non-Woven/LDPE with PET tape.**



# PPE KITS TAPES

- **Polyester Based Heat Sealable Tapes**
- **LDPE Based Cold Sealable (PSA) Tapes**
- **Heat Sealable Seam Sealing Tapes** are presently being imported and Chemline feel pride to be first Indian Company to Indigenously Develop and Manufacture these Tapes.



# PPE KITS TAPES



**Bio Suit, Sealant For Safety Gear ....**

# GENERAL PURPOSE MASKING TAPE

Crepe Paper Masking Tape provides excellent pressure sensitive and quick qualities and resistance to water, solvents and oils even at high temperature applications.

## FEATURES & BENEFITS

- High temperature Masking tape (up to 110°C)
- Residue free removal
- Writable grade
- Hand Tearable

## APPLICATION

Refrigeration, automotive & business machinery and many other places for Masking of painted metal, plastic & Rubber Surface where staining could be a problem and for other critical masking applications..



# RIGID PLASTIC PACKAGING

Chemline offers wide range of Blow Moulded and Injection Moulded products specifically for the Adhesives, Paints, Oil, Pesticide, chemical and various other industries.

Blow Moulding product range include

- 24 liters and 25 liters mouser canes
- 50 liters full open top drums
- 6" wide mouth 50 ltrs drum
- 65 liters Rocket drums

Injection Moulding

- 25 liters with weight 1.2 kg (inter locking buckets/pails)



50 Liters  
Full Open  
Top Drum



50 Liters Rocket



Narrow Mouth  
Mouser 25 Litres



6" Wide Mouth 50  
Litres Drum



Buckets / Conipails  
10,20,25 Liters

# OUR VALUED CUSTOMERS





## OUR VALUED CUSTOMERS



**BACARDI**



**PEPSICO**



Pernod Ricard India

**Carlsberg**



**KINGFISHER**  
THE REAL TASTE OF INDIA

**Bailey**

PACKAGED DRINKING WATER



**BIRA**<sup>®</sup>91



## CONCLUSION

- Chemline led the emerging Market trends in India for developing Newer Adhesives.
- Offers Widest Range of Products in the field of Adhesives, Coatings and Varnishes.
- “Progress through Innovation” is our motto.
- Chemline is committed to provide Eco-friendly products.
- Customer Delight is our top most goal.

**Thanks  
for  
Attention**

